

KVMN

1/2"-2"

Threaded sleeve

GENERAL FEATURES

- » Piston valve with bore
- » Sealing via two elastic KX-GT valve rings
- » Excellent control characteristics
- » Fire Safe
- » Special regulating design available (KVRKMN)

CONNECTIONS

DIN sleeved connections with pipe threads in accordance with ISO 228-1 (III, VIII), NPT sleeved connections in accordance with ANSI B2.1 (VIII)

DIMENSIONS

DIN 3202-M9

ACCEPTANCE TESTING

- » Seat leak tightness: EN 12266-1 P12, leakage rate A
- » Tightness to atmosphere: EN 12266-1 P11
- » Strength: EN 12266-1 P10

TEMPERATURE

-10 °C to +400 °C (see P-T diagram)

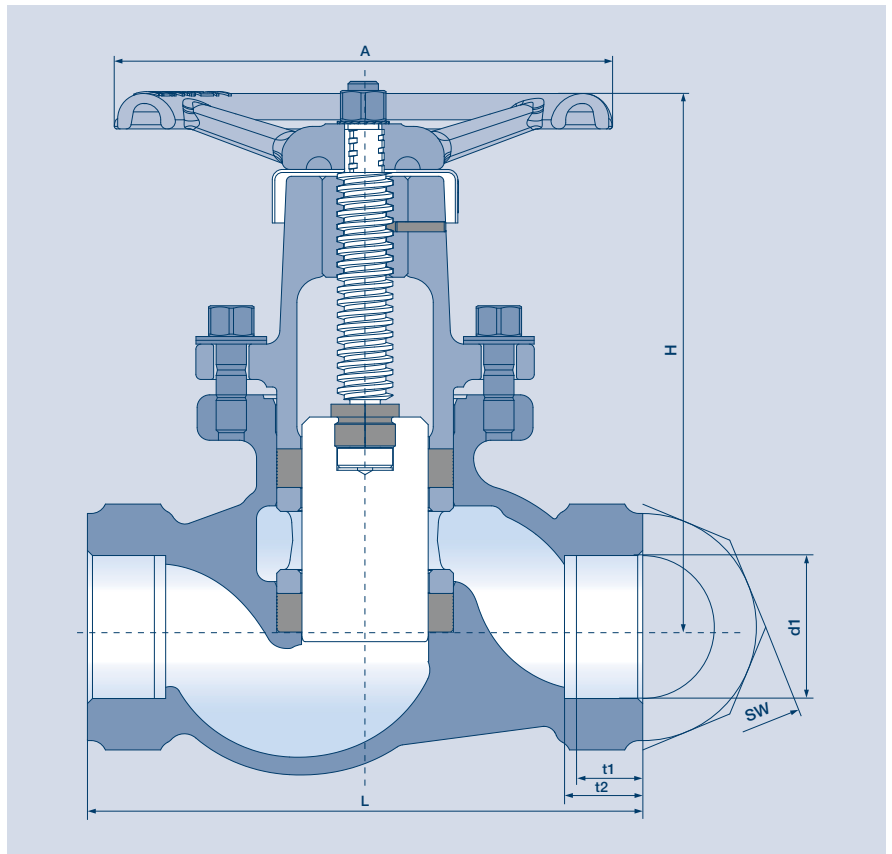

KVMN DESIGN

1/2"-2"

MATERIAL

- » Grey cast iron EN-GJL-250 / 5.1301 (Material code III)
- » Cast steel 1.0619 (Material code VIII)

DN	Dimensions			Hub	PN		Weight in kg	
	L	H	A		III	VIII	PN 16	PN 63

1/2"	100	105	100	23	16	63	1.6	1.8
3/4"	120	122	120	28	16	63	2.5	2.5
1"	135	140	140	34	16	63	3.6	3.7
1 1/4"	160	157	160	38	16	63	5.9	5.9
1 1/2"	185	184	180	45	16	63	8.4	8.6
2"	220	211	200	51	16	63	12.4	13.1

DN	DIN sleeved connections				NPT sleeved connections		
	d1	t1	t2	SW	d1	t1	t2

1/2"	G1/2"	15.5	19.5	36	1/2"-14NPT	13.5	19.5
3/4"	G3/4"	16	20	41	3/4"-14NPT	14	20
1"	G1"	17	22	50	1"-11 1/2NPT	17	24
1 1/4"	G1 1/4"	19	25	65	n.a.	n.a.	n.a.
1 1/2"	G1 1/2"	19	24	75	1 1/2"-11 1/2NPT	17	24.5
2"	G2"	26	31	90	2"-11 1/2NPT	18	25

n.a. – not available

Dimensions in mm. Subject to construction and design changes. NPT sleeved connections only available in cast steel design.